

DESCRIPTION

The DPW-692 Series Differential Pressure Transmitter is ideal for monitoring pumps and piping differential pressures in HVAC and process systems. The DPW-692 Series incorporates proven ceramic sensor technology, and the stainless steel housing is compatible with a wide variety of liquid or gas media. The convenient DIN 43650-A wiring connector makes installation easy and provides NEMA 4 (IP65) environmental protection.

FEATURES

- *Competitively priced*
- *Very high quality*
- *Short circuit proof*
- *Protection from reverse polarity*
- *Compact heavy duty housing*
- *True differential pressure sensing*
- *1/2" NPT conduit connector*
- *NEMA 4 (IP65) environmental rating*
- *Mounting bracket included*



DPW-692-100-KIT

SPECIFICATIONS	
Supply voltage	11-33 VDC
Output signal	Two-wire, 4-20 mA
Impedance	800 ohms at 24 VDC
Accuracy	< ±0.5% FS (includes linearity, hysteresis, and repeatability)
Wiring connections	DIN 43650-A connector with terminal blocks
Response time	< 5 ms
Temperature effects	< 0.1% FS/°C
Max differential port-to-port	≤ 0-100 psid ranges, 174 psid 0-200 psid range, 464 psi on HI, 174 psi on LO
Max system pressure	60 psid range and below; 362 psig (2500 kPa) 100 psid range and above; 725 psig (5000 kPa)
Rupture pressure	1.5 x max system pressure
Piping Connections	1/8" FNPT
Ambient and media temp rating	4° to 176°F (-15° to 80°C)
Wetted parts	303 stainless, FPM (Viton®) seals
NEMA ratings	NEMA 4 (IP65)
Approvals	CE
Weight	15 oz (430g)

Note: The DPW-692 can be calibrated ±10%; see installation instructions for this procedure. However, due to the very small recessed calibration screws, field calibration is difficult and not recommended. Kele can provide factory custom calibration; allow two weeks for delivery.

CAUTION: Not for use with ammonia.

DIMENSIONS

in
(mm)

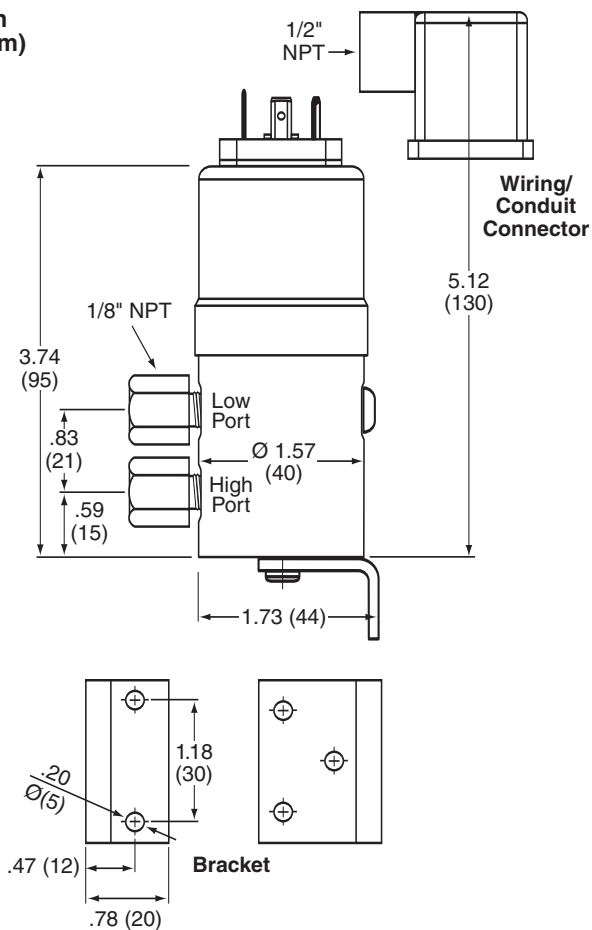

WIRING - 4-20 mA

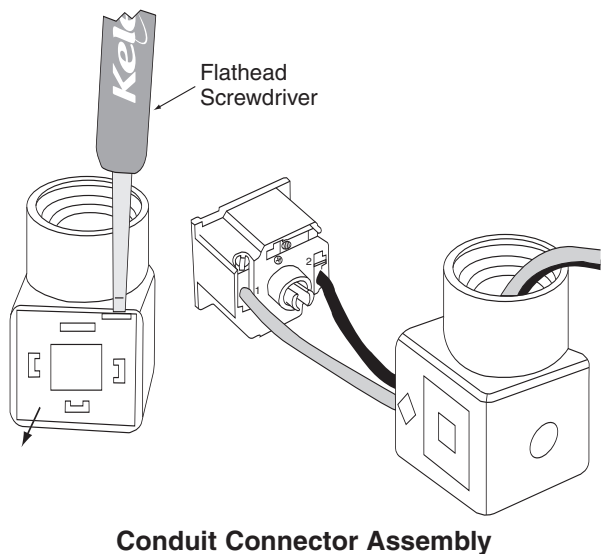
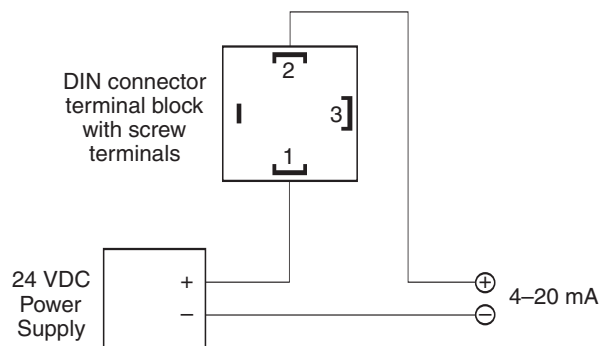

ORDERING INFORMATION

MODEL

DPW-692-25-KIT
DPW-692-35-KIT
DPW-692-60-KIT
DPW-692-100-KIT
DPW-692-200-KIT

DESCRIPTION

0-25 psid, 4-20 mA, 1/8" FNPT with bracket and conduit connector
0-35 psid, 4-20 mA, 1/8" FNPT with bracket and conduit connector
0-60 psid, 4-20 mA, 1/8" FNPT with bracket and conduit connector
0-100 psid, 4-20 mA, 1/8" FNPT with bracket and conduit connector
0-200 psid, 4-20 mA, 1/8" FNPT with bracket and conduit connector

Notes: To order a DPW-692 pre-assembled in a five-valve bypass enclosure, replace -KIT with -BVA suffix. To order a DPW-692 pre-assembled with a three-valve manifold, replace -KIT with -3VLV suffix.
To order a DPW-692 with factory custom range, add -C suffix to complete model number.
To order a DPW-692 for use with refrigerants, add -R suffix after -KIT. A neoprene seal is used in place of Viton®. Not applicable with -BVA or -3VLV assemblies.

RELATED PRODUCTS

101999
G5100-1101000

DPW-692 Series replacement mounting bracket w/screws
DIN 43650-A Replacement conduit connector w/gasket